



OLIMPIA Chemical Dosage Pump

OLIMPIA Chemical Dosage Pump is imported from Italy, a compact in size and user-friendly device that can be utilized in a wide range of industries and applications. Its versatility allows it to be used in diverse fields such as swimming pools, car washes, water treatment equipment, and cleaning equipment.



Features

- Fireproof and anti-acid polypropylene box
- 0 - 100% flow rate manual adjustment Manual priming valve
- Manual air eliminator
- 90 - 265 Vac power supply (24 V upon request)
- Power supply and level probe inlet with quick connection
- Working state LED
- IP 65 protection degree
- Possibility of customization on the pump body (on request)
- Comply with the regulations of the US Food and Drug Administration (FDA 21CFR 173.310), and can be used for sterilization of equipment in food factories.

Application

- Water supply: Pressure boosting for main pipes and high-rise buildings
- Industrial pressure boosting: Water system, cleaning system, high-pressure washing system
- Pressure boosting for pressure tank, sprinkler, and trickle irrigation systems
- Reverse Osmosis system high-pressure pump
- Air conditioner, cooling towers, and industrial cleaning.

Technical Data

Model	Flow Rate	Pressure	cc/stroke	Strokes/min.	Connections int/ext	Power cons.	Weight
Olimpia	2 l/h	7 bar	0.33	180	4/6 mm	15 watt	1.5 kg

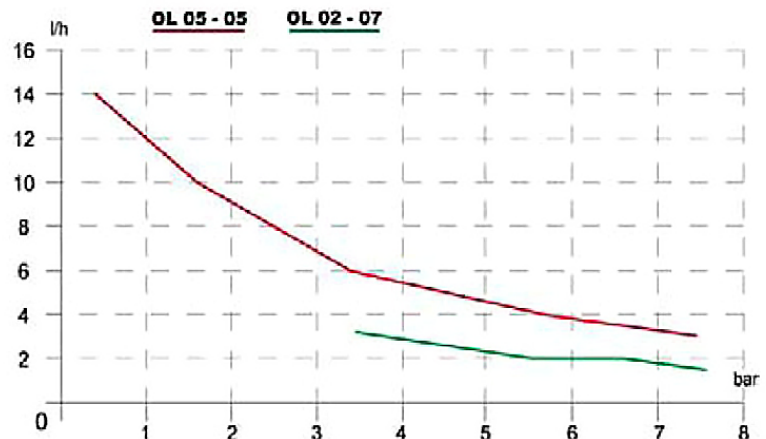
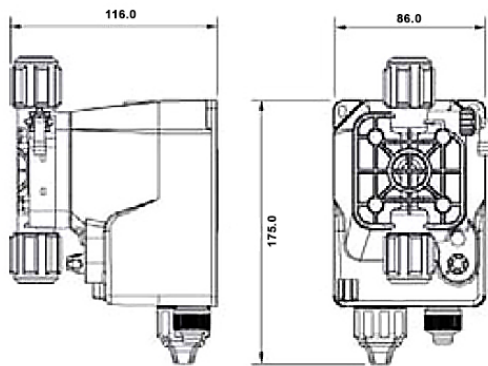



The Chemical Dosing System

Features

Our Chemical Dosing System comprises an Olympia Chemical Dosage Pump and a PE storage barrel.

The dosing flow is adjustable, and the barrel includes liquid-level protection control for precise dosing of various pharmaceuticals.

Sodium hypochlorite (NAOCL) is ideal for treating cooling water, pools, and wastewater, effectively controlling microorganism growth. It's FDA compliant (FDA 21CFR173.310), and suitable for disinfection, bleaching tap and pool water, and sterilizing food factory equipment.

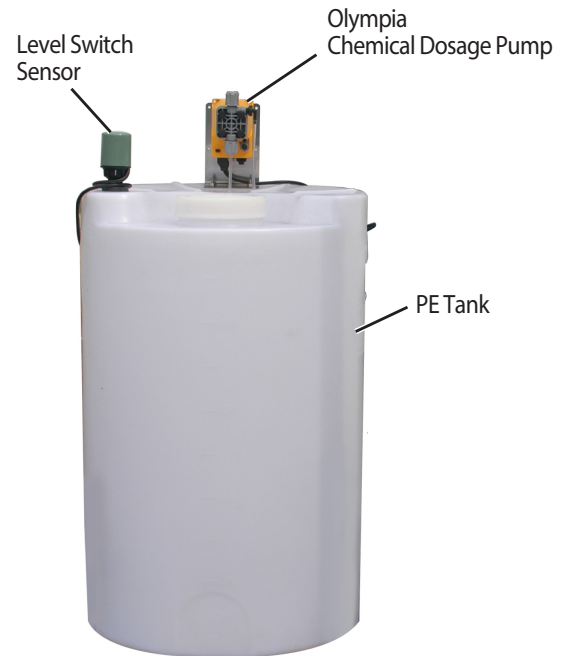

Installation Example

